

Model	Sorter Stapler (A377) for F400 / 410	Volt/Hz	Date of Modification	Serial Number
Modified Article	Parts Catalog			
Reason for Modification	Parts catalog correction			

Could you please correct your parts catalog as follows:

1. Parts number correction

Incorrect P/N	Correct P/N	Description	Q'ty Used	Parts Catalog	
				Index No.	Page
A3772111	A3772116	Lower Entrance Guide	1	2	9
A3772121	A3772126	Relay Guide	1	4	9
AA060551	A3772117	Pressure Spring	2	20	9

2. Elimination

Incorrect P/N	Description	Q'ty Used	Parts Catalog	
			Index No.	Page
54131875	Knob Screw	2 → 0	3	9
AA143059	Pin - 6 x 16	1 → 0	13	9
54131882	Stepped Screw	3 → 2	22	9

3. Addition

P/N	Description	Q'ty Used	Parts Catalog	
			Index No.	Page
A3772115	Lower Guide Mylar	2	27	9

3. Transport Section 2 (A377) ----- Page8

Elimination : Index No. 3, 13 and 22
Part Number Correction : Index No. 2, 4 and 20
Addition : Index No. 27

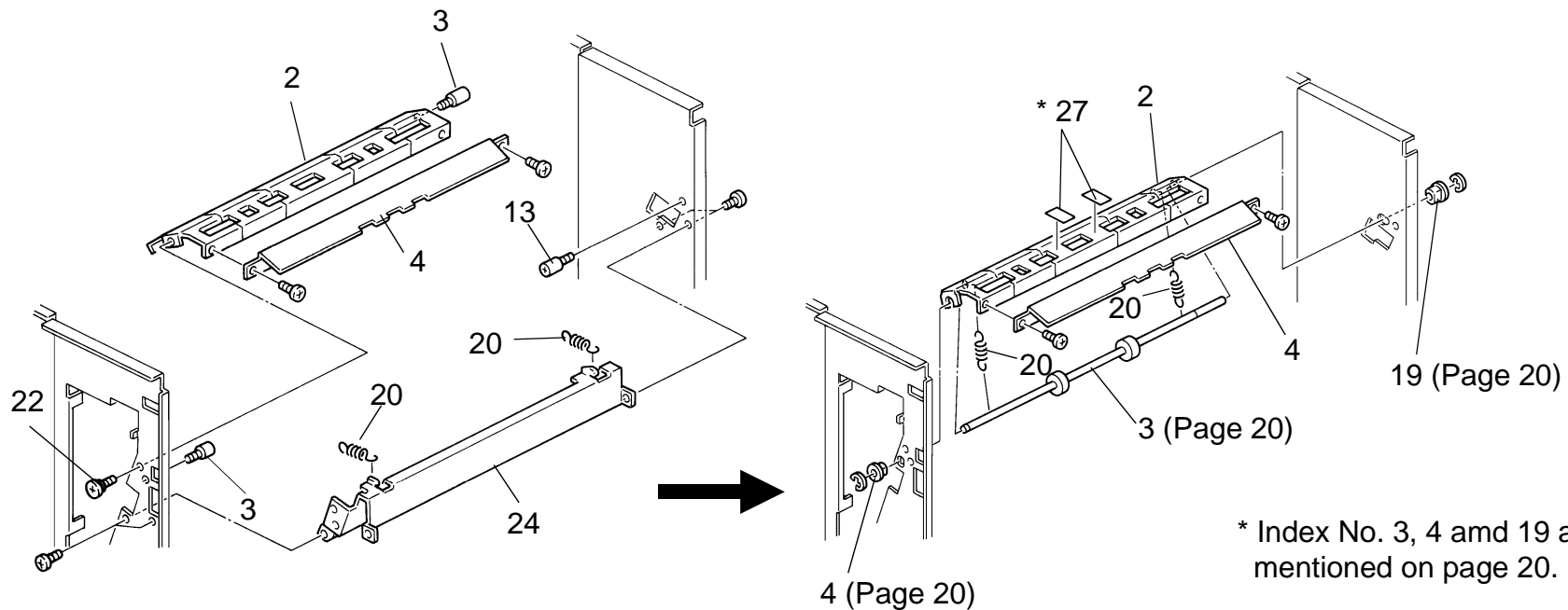

* Index No. 3, 4 and 19 are mentioned on page 20.

S. Hamano, Assistant General Manager
Technical Support Department

MODEL NAME	V/Hz	DESTINATION	JAPN PRODUCTION	
			CODE	SERIAL NUMBER
Savin Sorter Stapler 4	120/60	U.S.A.	A377 - 15	
Ricoh ST25	120/60	U.S.A. etc.	A377 - 17	
	230/50	Europe etc.		
NRG CSS55	120/60	U.S.A., Canada etc.	A377 - 22	
	230/50	Europe etc.		
Infotec SS204	230/50	Europe	A377 - 26	

Model		Sorter Stapler (A377) for F400/410					Volt/Hz	Date of Modification	Serial Number	
Modified Article		Top Cover								
Reason for Modification		Parts standardization								
Draw No.	Old Parts No.	New Parts No.	Description	Rank	Q'ty Used Old→New	Inter-changeability	Parts needed for replacement by new part		Parts Catalog	
							Part No.	Description	No.	Page
	A3771511	A3771710	Top Cover		1 → 1	O/O	△	RICOH	14	5
		A3771691	Clip Tray		0 → 1		/		* 28	5
	A3771513	A3771713	Top Cover		1 → 1	O/O	△	NRG	14	5
		A3771693	Clip Tray		0 → 1		/		* 28	5
	A3771514	A3771714	Top Cover		1 → 1	O/O	△	INFOTEC	14	5
		A3771694	Clip Tray		0 → 1		/		* 28	5
	A3771515	A3771715	Top Cover		1 → 1	O/O	△	SAVIN	14	5
		A3771695	Clip Tray		0 → 1		/		* 28	5

Rank: A : Replace with new parts immediately. B : Replace with new parts at time of repair. C : Replace with new parts at time of overhaul.

Interchangeability:

(1) When old and new parts are not mutually interchangeable, use additional parts or an assembly part as indicated in "Parts needed for replacement by new part" to install the new part.

(2) The mark to the left of the slash indicates whether the old part can be used in the new machine, and the mark to the right indicates whether the new part can be used in the old machine. x = Not interchangeable o = Interchangeable

DETAILS OF MODIFICATION

Due to standardization, the top cover has been changed.

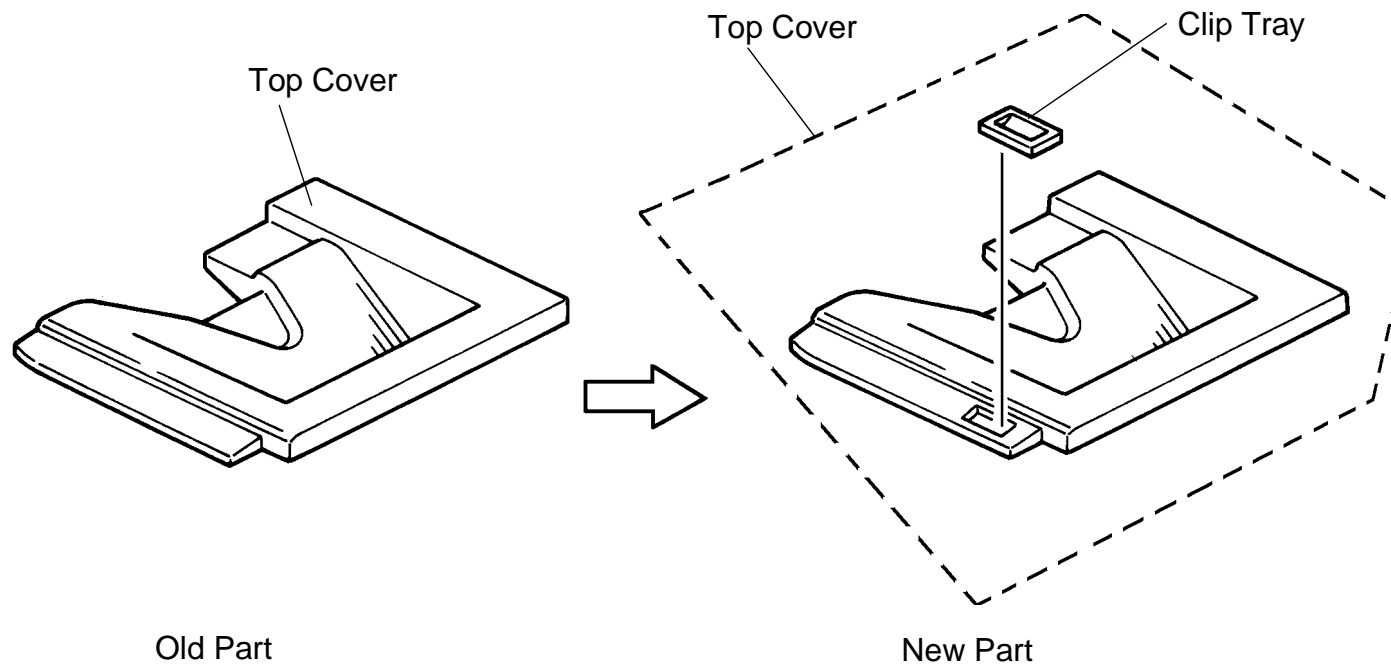

S. Hamano, Assistant General Manager
Technical Support Department

MODEL NAME	V/Hz	DESTINATION	JAPN PRODUCTION	
			CODE	SERIAL NUMBER
Savin Sorter Stapler 4	120/60	U.S.A.	A377 - 15	/
Ricoh ST25	120/60	U.S.A. etc.	A377 - 17	
	230/50	Europe etc.		
NRG CSS55	120/60	U.S.A. , Canada etc.	A377 - 22	
	230/50	Europe etc.		
Infotec SS204	230/50	Europe	A377 - 26	

Model	Sorter Stapler (A377) for F400/F410	Volt/Hz	Date of Modification	Serial Number
Modified Article	Idle Pulley Stud - Short			
Reason for Modification	To prevent the timing belt from coming off			

To prevent the timing belt from coming off, the idle pulley stud has been lengthened and the spacer has been added as shown.

Old P/N	New P/N	Description	Q'ty Used	Inter-changeability	Parts Catalog	
					Index No.	Page
A4693175		Idle Pulley Stud - Short	1 → 0	X/	14	13
	A3774726	Stepped Screw - M4 x 8 x 12	0 → 1	/O	14	13
	AA132152	Spacer - 8mm	0 → 1		* 24	13

* New Index

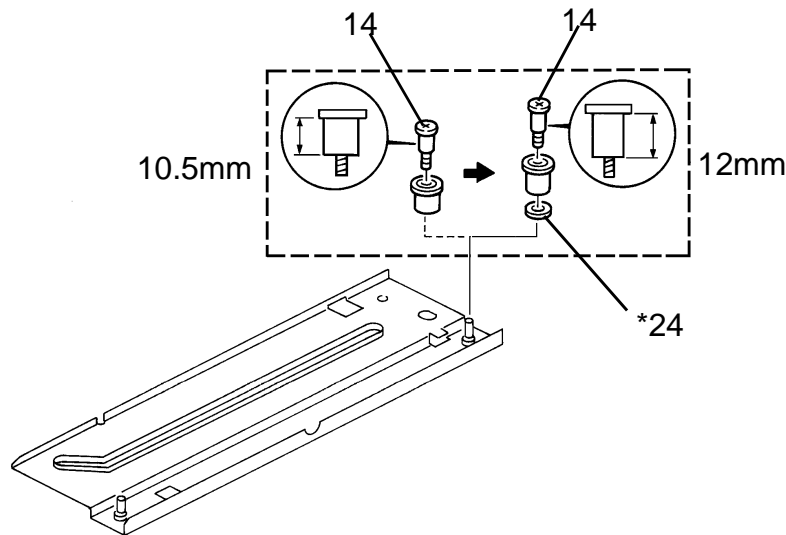

S. Hamano, Assistant General Manager
 Technical Support Department

MODEL NAME	V/Hz	DESTINATION	JAPAN PRODUCTION	
			CODE	SERIAL NUMBER
Savin Sorter Stapler 4	120/60	U.S.A.	A377 - 15	/
Ricoh ST25	120/60	U.S.A. etc.	A377 - 17	
	230/50	Europe etc.		
NRG CSS55	120/60	U.S.A. , Canada etc.	A377 - 22	
	230/50	Europe etc.		
Infotec SS204	230/50	Europe	A377 - 26	

Model	Sorter Stapler (A377) for F400/F410	Volt/Hz	Date of Modification	Serial Number
Modified Article	Parts Catalog			
Reason for Modification	Parts Catalog Correction			

Please correct your parts catalog as follows:

[Index number correction and addition in illustration] Page 6.

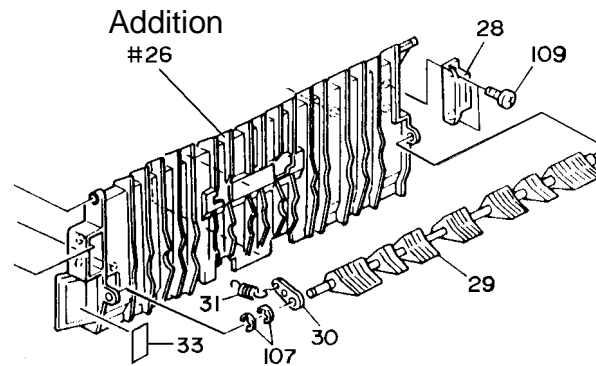
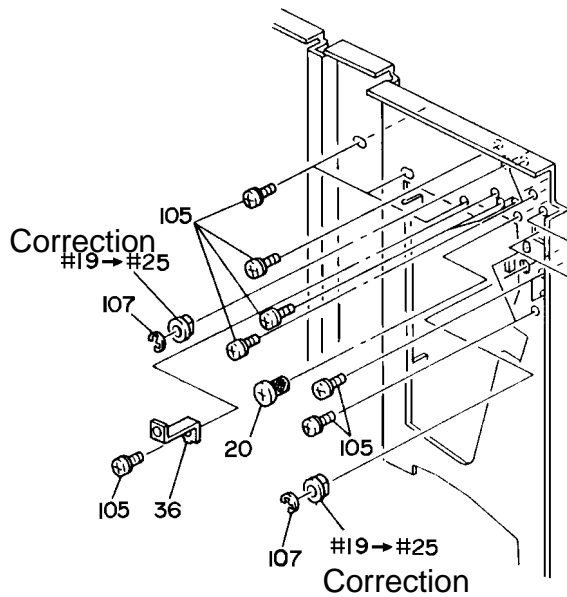

S. Hamano, Assistant General Manager
 Technical Support Department

MODEL NAME	V/Hz	DESTINATION	JAPAN PRODUCTION	
			CODE	SERIAL NUMBER
Savin Sorter Stapler 4	120/60	U.S.A.	A377 - 15	/
Ricoh ST25	120/60	U.S.A. etc.	A377 - 17	
	230/50	Europe etc.		
NRG CSS55	120/60	U.S.A. , Canada etc.	A377 - 22	
	230/50	Europe etc.		
Infotec SS204	230/50	Europe	A377 - 26	

Model	Sorter Stapler (A377) for F400/F410	Volt/Hz	Date of Modification	Serial Number
Modified Article	Lower Guide Mylar			
Reason for Modification	To facilitate manufacturing			

To facilitate manufacturing, the lower guide mylar has been removed.

Old P/N	New P/N	Description	Q'ty Used	Inter-change-ability	Parts Catalog	
					Index No.	Page
A3772115		Lower Guide Mylar	2 → 0		27	9

S. Hamano, Assistant General Manager
Technical Support Department

MODEL NAME	V/Hz	DESTINATION	JAPAN PRODUCTION	
			CODE	SERIAL NUMBER
Savin Sorter Stapler 4	120/60	U.S.A.	A377 - 15	/
Ricoh ST25	120/60	U.S.A. etc.	A377 - 17	
	230/50	Europe etc.		
NRG CSS55	120/60	U.S.A. , Canada etc.	A377 - 22	
	230/50	Europe etc.		
Infotec SS204	230/50	Europe	A377 - 26	

Model	Sorter Stapler (A377) for F400/F410	Volt/Hz	Date of Modification	Serial Number
Modified Article	Exit Roller			
Reason for Modification	To improve the paper delivery			

To improve the paper delivery, the exit rollers (4 rollers) have been modified.

Old P/N	New P/N	Description	Q'ty Used	Inter-change-ability	Parts Catalog	
					Index No.	Page
AF020307	A3772350	Exit Roller	1 → 1	X/O	8	7

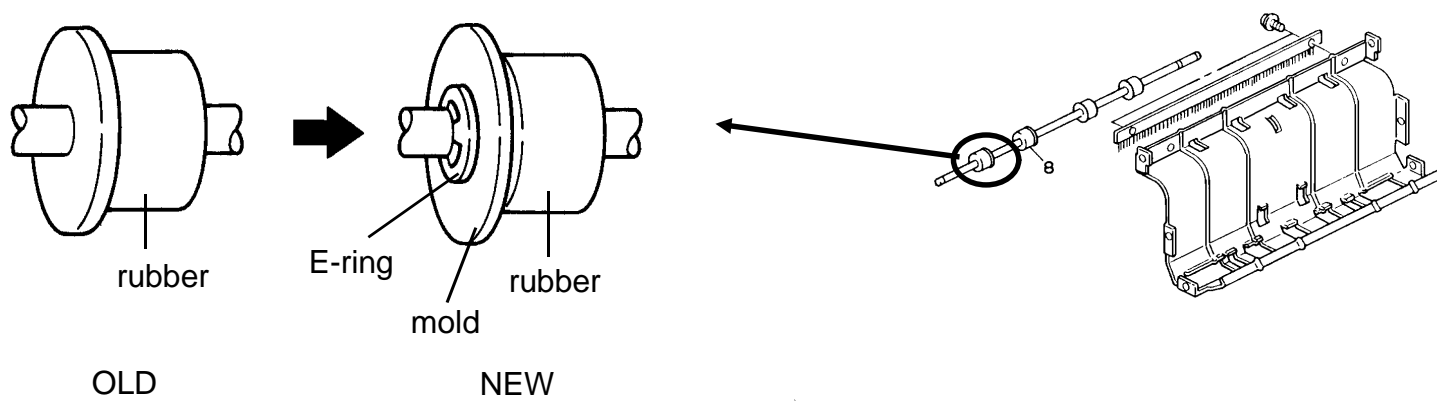

S. Hamano, Assistant General Manager
 Technical Support Department

MODEL NAME	V/Hz	DESTINATION	JAPAN PRODUCTION	
			CODE	SERIAL NUMBER
Savin Sorter Stapler 4	120/60	U.S.A.	A377 - 15	4133120001
Ricoh ST25	120/60	U.S.A. etc.	A377 - 17	A3393120001
	230/50	Europe etc.		
NRG CSS55	120/60	U.S.A. , Canada etc.	A377 - 22	5333120001
	230/50	Europe etc.		
Infotec SS204	230/50	Europe	A377 - 26	3D91230001

Model	Sorter Stapler (A377) for F400 / 410 / 420	Volt/Hz	Date of Modification	Serial Number
Modified Article	Lock Pin Spring			
Reason for Modification	To facilitate servicing			

To facilitate servicing, the outer diameter of the spring has been changed from 7 mm to 6.5 mm. When using the old part, it is difficult put onto the bushing.

Old P/N	New P/N	Description	Q'ty Used	Inter-change-ability	Parts Catalog	
					Index No.	Page
A4582479	AA063529	Lock Pin Spring	8	X/	4 7	7 9
		Pressure Spring - 14.5 mm	8	O/	4 7	7 9

S. Hamano, Assistant General Manager
 Technical Support Department

MODEL NAME	V/Hz	DESTINATION	JAPAN PRODUCTION	
			CODE	SERIAL NUMBER
Savin Sorter Stapler 4	120/60	U.S.A.	A377 - 15	4134020001
Ricoh ST25	120/60	U.S.A. etc.	A377 - 17	A3394020001
	230/50	Europe etc.		
NRG CSS55	120/60	U.S.A. , Canada etc.	A377 - 22	5334020001
	230/50	Europe etc.		
Infotec SS204	230/50	Europe	A377 - 26	3D90240001

Model	Sorter Stapler (A377) for F400 / 410 / 420	Volt/Hz	Date of Modification	Serial Number
Modified Article	Lower Sensor Cover			
Reason for Modification	To prevent the malfunction of the sensor caused by reflected light			

To prevent the malfunction of the sensor caused by reflected light, the lower sensor cover has been added.

New P/N	Description	Q'ty Used	Parts Catalog	
			Index No.	Page
A3771666	Lower Sensor Cover	0 → 1	* 24	21
09504006B	Screw - M4 x 6	n - n+1	104	21

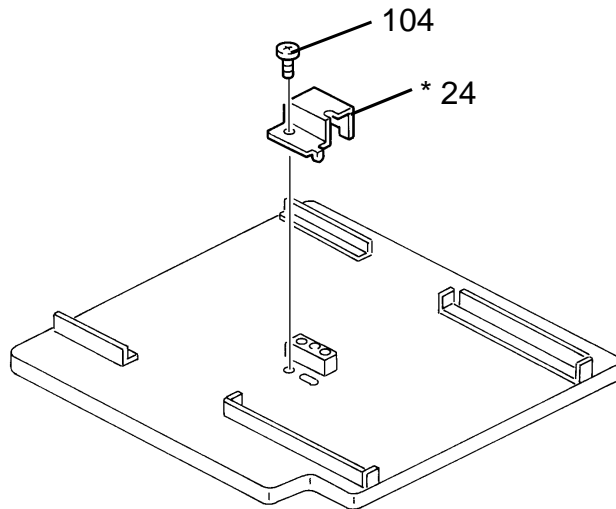

S. Hamano, Assistant General Manager
 Technical Support Department

MODEL NAME	V/Hz	DESTINATION	JAPAN PRODUCTION	
			CODE	SERIAL NUMBER
Savin Sorter Stapler 4	120/60	U.S.A.	A377 - 15	4134060001
Ricoh ST25	120/60	U.S.A. etc.	A377 - 17	A3394060001
	230/50	Europe etc.		
NRG CSS55	120/60	U.S.A. , Canada etc.	A377 - 22	5334060001
	230/50	Europe etc.		
Infotec SS204	230/50	Europe	A377 - 26	3D90640001

Model	Sorter Stapler (A377) for F400 / 410 / 420	Volt/Hz	Date of Modification	Serial Number
Modified Article	Timing Pulley etc.			
Reason for Modification	To reduce the mechanical driving noise			

To reduce the mechanical driving noise, the stepping motor cushion has been added and the timing pulley has been changed. When install the cushion, the timing pulley should be replaced with new one.

Old P/N	New P/N	Description	Q'ty Used	Inter-changeability	Parts Catalog	
					Index No.	Page
AB030216	AB030516	Timing Pulley - 15Z	1 → 1	X/X	18	11
	10050944	Stepping Motor Cushion	0 → 1	as a set X/O	* 112	11
	03130050B	Philips Pan Head Screw - M3 x 5	n - n+1		105	11
	A3545230	Grounding Harness	0 → 1		* 34	

* New Index

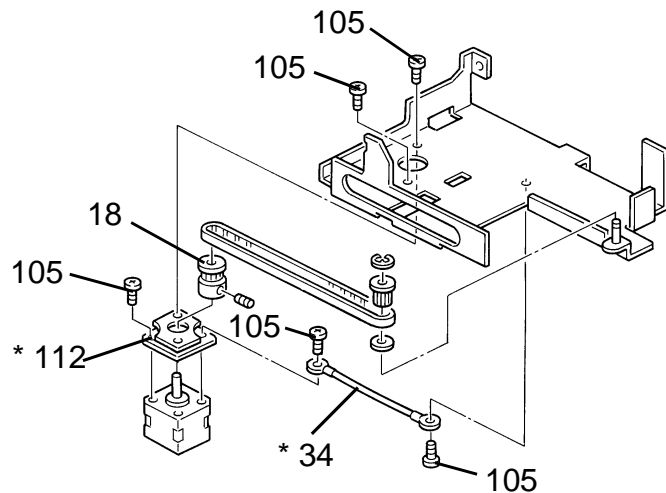

S. Hamano, Assistant General Manager
 Technical Support Department

MODEL NAME	V/Hz	DESTINATION	JAPAN PRODUCTION	
			CODE	SERIAL NUMBER
Savin Sorter Stapler 4	120/60	U.S.A.	A377 - 15	4134090001
Ricoh ST25	120/60	U.S.A. etc.	A377 - 17	A3394080067
	230/50	Europe etc.		
NRG CSS55	120/60	U.S.A. , Canada etc.	A377 - 22	5334080001
	230/50	Europe etc.		
Infotec SS204	230/50	Europe	A377 - 26	3D90840001

Model	Sorter Stapler (A377) for F400 / 410 / 420	Volt/Hz	Date of Modification	Serial Number
Modified Article	Cushion - T 1.2			
Reason for Modification	To reduce the mechanical driving noise			

To reduce the mechanical driving noise, the cushions have been added and the fixing screws have been changed. When installing the cushion, the new fixing screw should be used.

Old P/N	New P/N	Description	Q'ty Used	Inter-changeability	Parts Catalog	
					Index No.	Page
	A3772217	Cushion - T 1.2	0 → 4		* 44	19
09504006B		Screw - M4 x 6	4 → 0		101	19
		54036246	Stepped Screw - Cleaning		0 → 4	* 45

* New Index

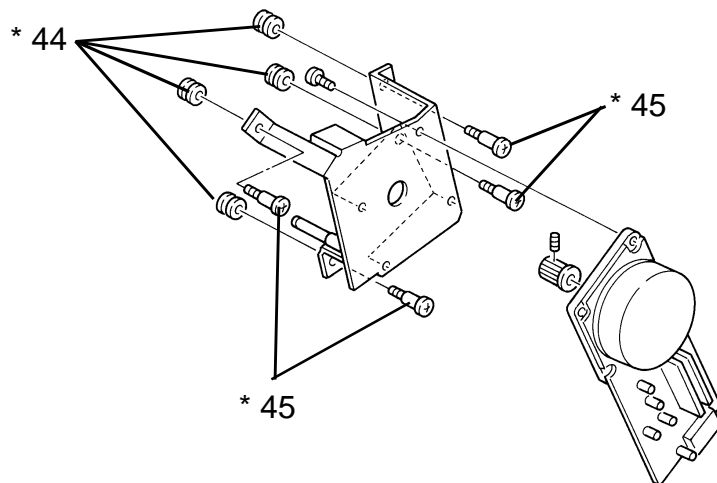

S. Hamano, Assistant General Manager
 Technical Support Department

MODEL NAME	V/Hz	DESTINATION	JAPAN PRODUCTION	
			CODE	SERIAL NUMBER
Savin Sorter Stapler 4	120/60	U.S.A.	A377 - 15	4134070001
Ricoh ST25	120/60	U.S.A. etc.	A377 - 17	A3394061537
	230/50	Europe etc.		
NRG CSS55	120/60	U.S.A. , Canada etc.	A377 - 22	5334070001
	230/50	Europe etc.		
Infotec SS204	230/50	Europe	A377 - 26	3D90740001

Model	Sorter Stapler for F400 / 410 / 420	Volt/Hz	Date of Modification	Serial Number
Modified Article	Bins and Guide Rollers			
Reason for Modification	To prevent the guide rollers from coming off			

Draw No.	Old Parts No.	New Parts No.	Description	Rank	Q'ty Used Old→New	Inter-changeability	Parts needed for replacement by new part		Parts Catalog	
							Part No.	Description	No.	Page
	A3773410	A3773510	Bin Ass'y	C	20 → 20	X/X	-17 version only -15, -22, -26 versions only	x/o as a set	8	5
	A3773413	A3773513	Bin Ass'y	C	20 → 20	X/X			8	5
	A3773460	A3773560	Supporting Bin	C	1 → 1	X/X			5	5
	A3773446	A3773546	Guide Roller	C	63 → 63	X/X			7	5

Rank: A : Replace with new parts immediately. B : Replace with new parts at time of repair. C : Replace with new parts at time of overhaul.
 Interchangeability:
 (1) When old and new parts are not mutually interchangeable, use additional parts or an assembly part as indicated in "Parts needed for replacement by new part" to install the new part.
 (2) The mark to the left of the slash indicates whether the old part can be used in the new machine, and the mark to the right indicates whether the new part can be used in the old machine. x = Not interchangeable o = Interchangeable

DETAILS OF MODIFICATION

The bin guide roller may come off the bin shaft when a customer attempts to remove a jammed sheet of paper while lifting the bin up too much, as if a customer hits the bin.

To prevent this problem happening even under the above conditions, the shaft of the bin and the guide roller have been modified to be engaged as shown in the following illustration.

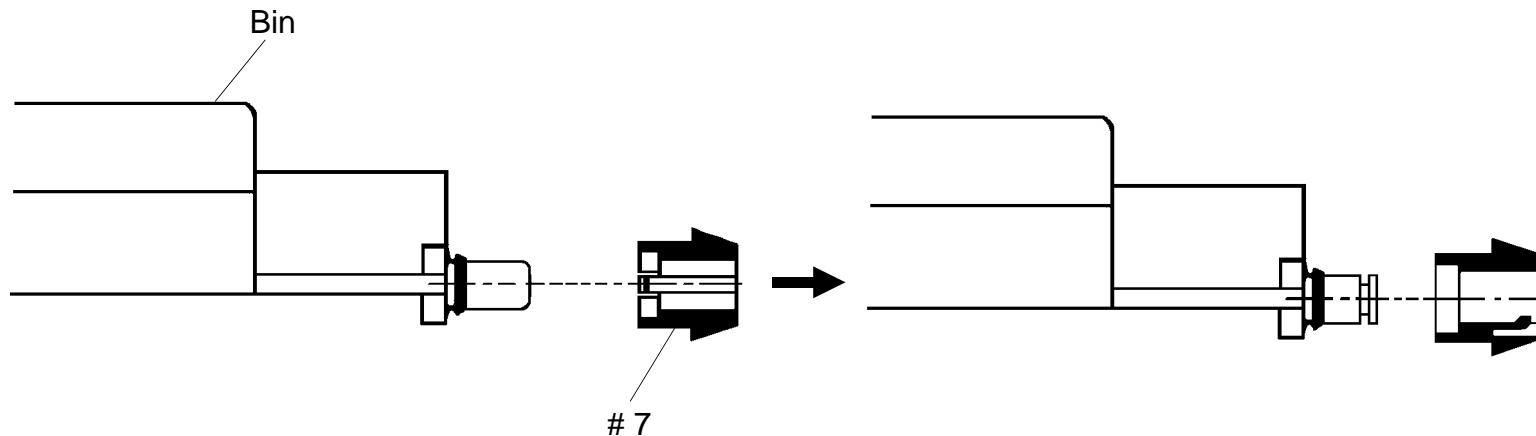

S. Hamano, Assistant General Manager
Technical Support Department

MODEL NAME	V/Hz	DESTINATION	JAPAN PRODUCTION	
			CODE	SERIAL NUMBER
Savin Sorter Stapler 4	120/60	U.S.A.	A377 - 15	4135010001
Ricoh ST25	120/60	U.S.A. etc.	A377 - 17	A3395010961
	230/50	Europe etc.		
NRG CSS55	120/60	U.S.A. , Canada etc.	A377 - 22	5335010001
	230/50	Europe etc.		
Infotec SS204	230/50	Europe	A377 - 26	3D90150001

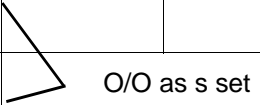
Model		Sorter Stapler for F400 / 410 / 420					Volt/Hz	Date of Modification	Serial Number	
Modified Article		Entrance Guide etc.								
Reason for Modification		Part standardization with other models								
Draw No.	Old Parts No.	New Parts No.	Description	Rank	Q'ty Used Old→New	Inter-changeability	Parts needed for replacement by new part		Parts Catalog	
							Part No.	Description	No.	Page
	A3772126	A6062126	Entrance Guide	C	1 → 1	O/O			4	9
	A3771141	A6061141	Upper Stay	C	1 → 1	O/O			3	7
	A3771171	A6061171	Exit Stay	C	1 → 1	O/O			16	9
	A3771571	A3771721	Front Door	C	1 → 1	O/O	(-17)		1	5
	A3771573	A3771723	Front Door	C	1 → 1	O/O	(-22)		1	5
	A3771574	A3771724	Front Door	C	1 → 1	O/O	(-26)		1	5
	A3771575	A3771725	Front Door	C	1 → 1	O/O	(-15)		1	5
	A3772116	A6062182	Lower Entrance Guide	C	1 → 1	O/O			2	9
	58874195	AA143462	Stopper Screw	C	3 → 3	X/O			17	21
	58874185	AB033070	Idler Pulley	C	2 → 2	X/O				19
	A3372340	A6062340	Junction Gate Solenoid	C	1 → 1	O/O			2	19

Rank: A : Replace with new parts immediately. B : Replace with new parts at time of repair. C : Replace with new parts at time of overhaul.

Interchangeability:

- (1) When old and new parts are not mutually interchangeable, use additional parts or an assembly part as indicated in "Parts needed for replacement by new part" to install the new part.
- (2) The mark to the left of the slash indicates whether the old part can be used in the new machine, and the mark to the right indicates whether the new part can be used in the old machine. x = Not interchangeable o = interchangeable

DETAILS OF MODIFICATION

The parts listed on the front part list pages have been changed for part standardization with other models.

The location of the two parts newly added is shown in the illustration below.

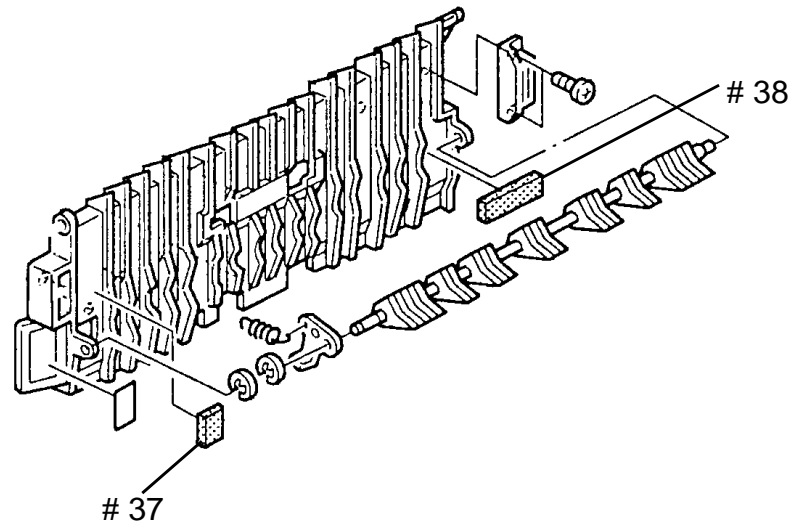

M. Iwasa, Manager
Technical Support Department

MODEL NAME	V/Hz	DESTINATION	JAPAN PRODUCTION	
			CODE	SERIAL NUMBER
Savin Sorter Stapler 4	120/60	U.S.A.	A377 - 15	4135070167
Ricoh ST25	120/60	U.S.A. etc.	A377 - 17	A3395070001
	230/50	Europe etc.		
NRG CSS55	120/60	U.S.A. , Canada etc.	A377 - 22	5335070064
	230/50	Europe etc.		
Infotec SS204	230/50	Europe	A377 - 26	3D9085XXXX

Model	Sorter Stapler for F400 / 410 / 420	Volt/Hz	Date of Modification	Serial Number
Modified Article	Pressure Spring			
Reason for Modification	Part standardization			

The following part has been changed to standardize with other models.

Old P/N	New P/N	Description	Q'ty Used	Inter-change-ability	Parts Catalog	
					Index No.	Page
A3772117	AA060657	Pressure Spring	2 → 2	O/O	20	9

M. Iwasa, Manager
 Technical Support Department

MODEL NAME	V/Hz	DESTINATION	JAPAN PRODUCTION	
			CODE	SERIAL NUMBER
Savin Sorter Stapler 4	120/60	U.S.A.	A377 - 15	4135090001
Ricoh ST25	120/60	U.S.A. etc.	A377 - 17	A3395090001
	230/50	Europe etc.		
NRG CSS55	120/60	U.S.A. , Canada etc.	A377 - 22	5335090001
	230/50	Europe etc.		
Infotec SS204	230/50	Europe	A377 - 26	3D90950001

Model	Sorter Stapler for F400 / 410 / 420	Volt/Hz	Date of Modification	Serial Number
Modified Article	Stud Screw			
Reason for Modification	To hold the helical wheels securely			

To prevent the helical wheels from coming out of position during transportation, stud screws have been added.

Old P/N	New P/N	Description	Q'ty Used	Inter-change-ability	Parts Catalog	
					Index No.	Page
	A3771116	Stud Screw - M6	0 → 3	—	33	14

NOTE: Stud screws cannot be installed on the old type machines.

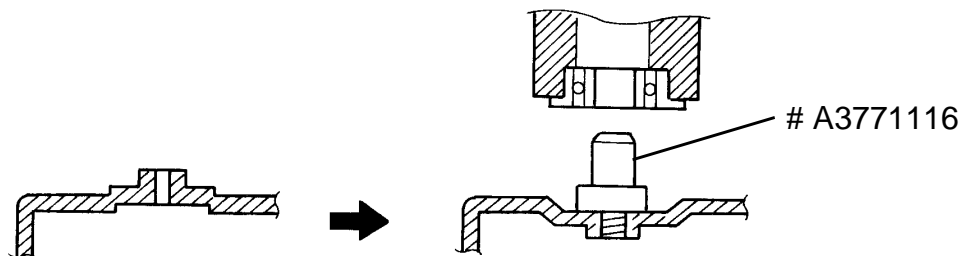

M. Iwasa, Manager
 Technical Support Department

MODEL NAME	V/Hz	DESTINATION	JAPAN PRODUCTION	
			CODE	SERIAL NUMBER
Savin Sorter Stapler 4	120/60	U.S.A.	A377 - 15	4135060001
Ricoh ST25	120/60	U.S.A. etc.	A377 - 17	A3395060001
	230/50	Europe etc.		
NRG CSS55	120/60	U.S.A. , Canada etc.	A377 - 22	5335060001
	230/50	Europe etc.		
Infotec SS204	230/50	Europe	A377 - 26	3D90650001

Model	Sorter Stapler for F400 / 410 / 420	Volt/Hz	Date of Modification	Serial Number
Modified Article	Hinge			
Reason for Modification	Part Standardization			

The following part has been changed to standardize with other models.

Old P/N	New P/N	Description	Q'ty Used	Inter-change-ability	Parts Catalog	
					Index No.	Page
A3771645	A6061645	Hinge	1 → 1	O/O	2	5

M. Iwasa, Manager
Technical Support Department

MODEL NAME	V/Hz	DESTINATION	JAPAN PRODUCTION	
			CODE	SERIAL NUMBER
Savin Sorter Stapler 4	120/60	U.S.A.	A377 - 15	413
Ricoh ST25	120/60	U.S.A. etc.	A377 - 17	A339
	230/50	Europe etc.		
NRG CSS55	120/60	U.S.A. , Canada etc.	A377 - 22	533
	230/50	Europe etc.		
Infotec SS204	230/50	Europe	A377 - 26	3D9

Model		Sorter Stapler F400 / 410 / 420					Volt/Hz	Date of Modification	Serial Number	
Modified Article		Upper Inner Cover								
Reason for Modification		To prevent malfunction								
Draw No.	Old Parts No.	New Parts No.	Description	Rank	Q'ty Used Old→New	Inter-changeability	Parts needed for replacement by new part		Parts Catalog	
							Part No.	Description	No.	Page
	A3771621	A3771623	Upper Inner Cover		1 → 1	X/O			1	9
		A3771624	Cushion		0 → 1				* 28	9
								* New Index #		

Rank: A : Replace with new parts immediately. B : Replace with new parts at time of repair. C : Replace with new parts at time of overhaul.

Interchangeability:

(1) When old and new parts are not mutually interchangeable, use additional parts or an assembly part as indicated in "Parts needed for replacement by new part" to install the new part.

(2) The mark to the left of the slash indicates whether the old part can be used in the new machine, and the mark to the right indicates whether the new part can be used in the old machine. x = Not interchangeable o = Interchangeable

DETAILS OF MODIFICATION

The LED light reflects off the upper inner cover and may activate the photosensor when all bins are at the high position. This causes the twentieth sets of copies not to be stapled.

To prevent this malfunction, the upper inner cover has been bent so that the light will not reach the photosensor.

The cushion has been added to the end of the bent portion so that the roller will not be exposed.

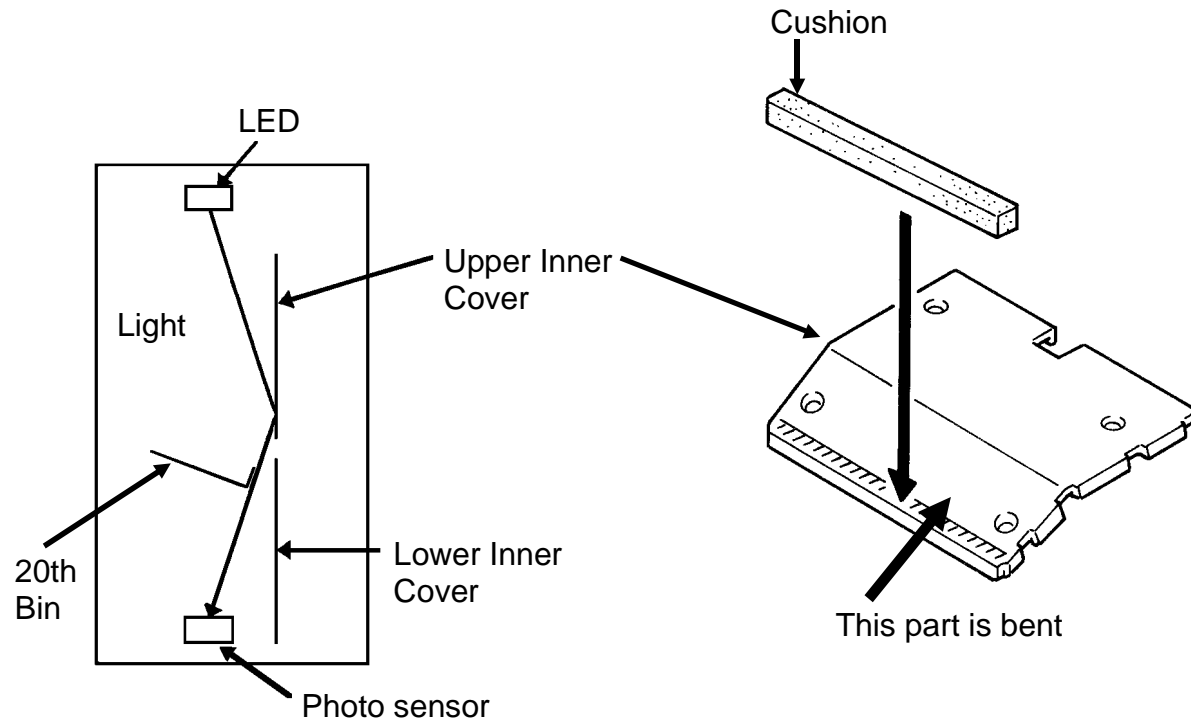

M. Iwasa, Manager
 Technical Support Department

MODEL NAME	V/Hz	DESTINATION	JAPAN PRODUCTION	
			CODE	SERIAL NUMBER
Savin Sorter Stapler 4	120/60	U.S.A.	A377 - 15	413512XXXX
Ricoh ST25	120/60	U.S.A. etc.	A377 - 17	A339512XXXX
	230/50	Europe etc.		
NRG CSS55	120/60	U.S.A. , Canada etc.	A377 - 22	5335110142
	230/50	Europe etc.		
Infotec SS204	230/50	Europe	A377 - 26	3D9125XXXX

Model	Sorter Stapler for F400 / 410	Volt/Hz	Date of Modification	Serial Number
Modified Article	Middle Stay			
Reason for Modification	Part Standardization			

To standardize with other models, the following part has been changed:

Old P/N	New P/N	Description	Q'ty Used	Inter-change-ability	Parts Catalog	
					Index No.	Page
A3771181	A6061181	Middle Stay	1 → 1	O/O	19	9



T. Inoue, General Manager
1st Field Information Dept. QAC

MODEL NAME	V/Hz	DESTINATION	JAPAN PRODUCTION	
			CODE	SERIAL NUMBER
Savin Sorter Stapler 4	120/60	U.S.A.	A377 - 15	413
Ricoh ST25	120/60	U.S.A., etc.	A377 - 17	A339
	230/50	Europe, etc.		
NRG CSS55	120/60	U.S.A. , Canada, etc.	A377 - 22	533
	230/50	Europe, etc.		
Infotec SS204	230/50	Europe	A377 - 26	3D9

Model	Sorter Stapler for F400 / 410 / 420	Volt/Hz	Date of Modification	Serial Number
Modified Article	Hexagon Headless Set Screw - M4 x 4			
Reason for Modification	To prevent the hexagon screw from becoming loose.			

Old P/N	New P/N	Description	Q'ty Used	Inter-changeability	Parts Catalog	
					Index No.	Page
05740040E		Hexagon Headless Set Screw - M4 x 4	n → n-1	X/	101	17
	A3773255	Hexagon Headless Set Screw - M4 x 4	0 → 1	/O	* 36	17

* New Index

To prevent the hexagon screw from becoming loose, it has been changed to the Nylock type.

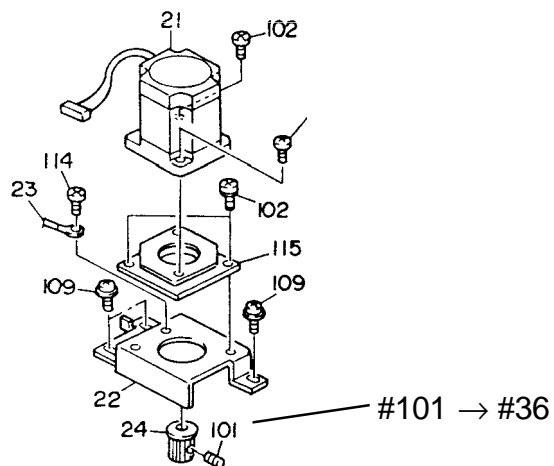

T. Inoue
 T. Inoue, General Manager
 1st Field Information Dept. QAC

MODEL NAME	V/Hz	DESTINATION	JAPAN PRODUCTION	
			CODE	SERIAL NUMBER
Savin Sorter Stapler 4	120/60	U.S.A.	A377 - 15	413608XXXX
Ricoh ST25	120/60	U.S.A., etc.	A377 - 17	A3396070001
	230/50	Europe, etc.		
NRG CSS55	120/60	U.S.A. , Canada, etc.	A377 - 22	5336070001
	230/50	Europe, etc.		
Infotec SS204	230/50	Europe	A377 - 26	3D9086XXXX

Model: Sorter Stapler for F400/410/420		Date: 15-Feb-98	No: 19
Modified Article: Gripper Solenoid Bracket etc		Prepared by: F.Noguchi	
From: QAC Field Information Dept.			
Reason for Modification:	<input type="checkbox"/> Parts catalog correction	<input type="checkbox"/> Vendor change	<input type="checkbox"/> To meet standards
	<input type="checkbox"/> To facilitate assembly	<input type="checkbox"/> To improve reliability	()
	<input checked="" type="checkbox"/> Part standardization	<input type="checkbox"/> Other	

Old part number	New part number	Description	Qty	Int	Page	Index	Note
A6061141	A6641141	Upper Stay	1-1	O/O	7	3	
AF022068	AF022097	Driven Roller	8-8	O/O	7	6	
			4-4	O/O	9	10	
A3772311	A6642311	Right Guide Plate	1-1	O/O	7	10	
A3771151	A6641151	Stay	2-2	O/O	7	23	
			1-1	O/O	21	5	
A3772131	A6642131	Right Lower Guide	1-1	O/O	9	12	
A3771126	A6641126	Front Cover Plate	1-1	O/O	9	24	
A6061171	A6641171	Exit Stay	1-1	O/O	9	16	
A6061181	A6641181	Middle Stay	1-1	O/O	9	19	
A3774436	A6644436	Gripper Solenoid Bracket	1-1	O/O	11	7	
A6064441	A6644441	Slider Support Bracket	1-1	O/O	11	26	
A3774721	A3774751	Stapler Slide Bracket	1-1	O/O	13	23	
A3774745	A6644745	Harness Cover	1-1	O/O	13	10	
A3773311	A6643311	End Fence Bracket	1-1	O/O	19	28	
A3774131	A6644131	Upper Jogger Stay	1-1	O/O	15	24	
A3774133	A6644133	Lower Jogger Stay	1-1	O/O	17	2	

Due to part standardization, the parts listed above have been changed.

Model: Sorter Stapler for F400/410/420

Date: 15-Feb-98

No: 19

MODEL NAME	V/ Hz	DESTINATION	CODE	SERIAL NUMBER
Savin Sorter Stapler 4	120/ 60	U. S. A.	A377 - 15	/
Ricoh ST25	120/ 60	U. S. A., etc.	A377 - 17	
	230/ 50	Europe, etc.		
NRG CSS55	120/ 60	U. S. A. , Canada, etc.	A377 - 22	
	230/ 50	Europe, etc.		
Infotec SS204	230/ 50	Europe	A377 - 26	

Model: Sorter Stapler for F400/410/420		Date: 31-Jul-98	No: 20
Modified Article: Front Cover Plate		Prepared by: F.Noguchi	
From: QAC Field Information Dept.			
Reason for Modification:	<input type="checkbox"/> Parts catalog correction <input type="checkbox"/> Vendor change <input type="checkbox"/> To meet standards <input checked="" type="checkbox"/> To facilitate assembly <input type="checkbox"/> To improve reliability () <input type="checkbox"/> Part standardization <input type="checkbox"/> Other		

Old part number	New part number	Description	Qty	Int	Page	Index	Note
A6641126	A3771126	Front Cover Plate	1	O/O	9	24	

The three holes in the front cover plate for the screws to secure it were designed for tapping screws so when the front cover plate was attached to the side frame it also rotated when the screws were tightened. The three holes have been changed to suit M4 screws.

Model: Sorter Stapler for F400/410/420		Date: 31-Aug-98	No: 21
Modified Article: Left Lower Guide		Prepared by: F.Noguchi	
From: QAC Field Information Dept.			
Reason for Modification:	<input type="checkbox"/> Parts catalog correction	<input type="checkbox"/> Vendor change	<input type="checkbox"/> To meet standards
	<input type="checkbox"/> To facilitate assembly	<input type="checkbox"/> To improve reliability	()
	<input checked="" type="checkbox"/> Part standardization	<input type="checkbox"/> Other	

Old part number	New part number	Description	Qty	Int	Page	Index	Note
A3772141	A8212141	Left Lower Guide	1	X/X	9	9	•
54131882		Stepped Screw	3-2	X/	9	22	
	A8212151	Stopper-Guide Plate-Left Lower	0-1	/X	9	*29	•
A6641171	A8211171	Exit Stay	1	O/O	9	16	
A3771636	A8211636	Upper Rear Cover Bracket	1	O/O	19	1	

*New Index

Due to parts standardization, the above parts have been changed.

- Note: Due to a change in the mold of the Left Lower Guide (A3772141), the old one can no longer be supplied. When installing the new Left Lower Guide (A8212141), please use the Stopper -Guide Plate-Left Lower (A8212151).

Page 8

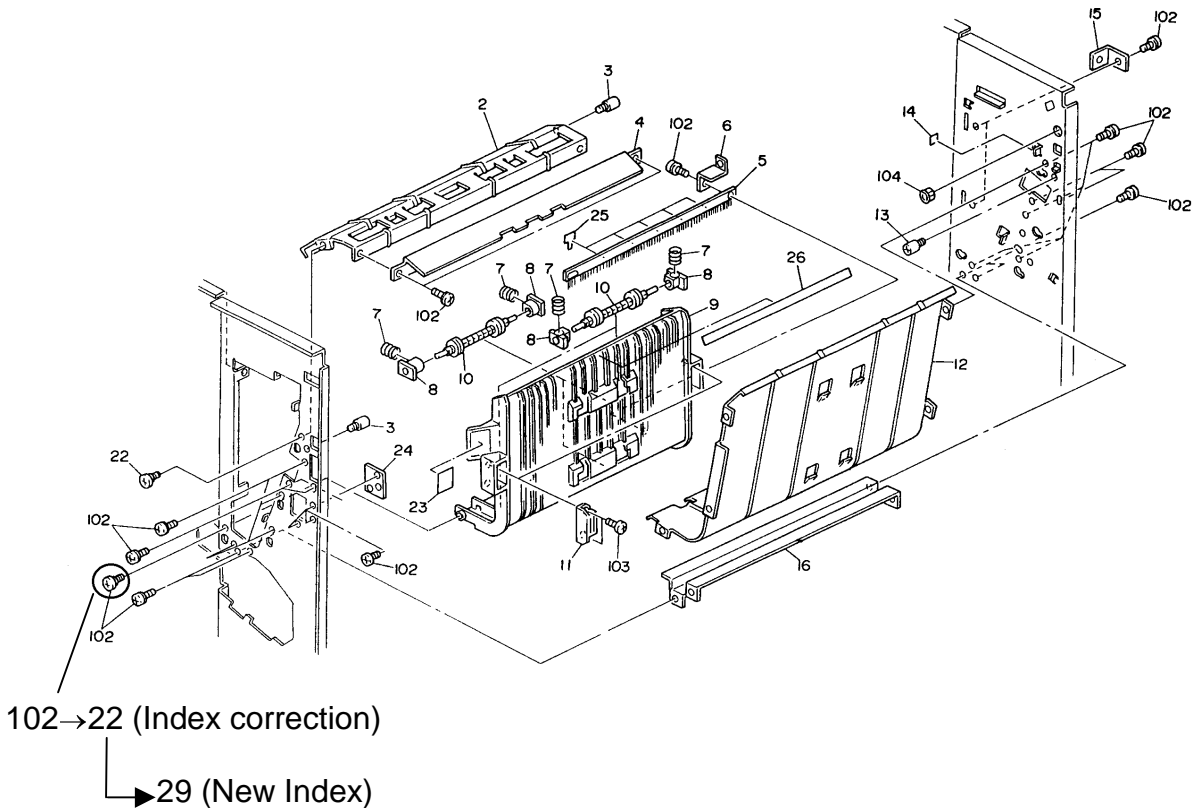

Model: Sorter Stapler for F400/410/420

Date: 31-Aug-98

No: 21

MODEL NAME	V/ Hz	DESTINATION	CODE	SERIAL NUMBER
Savin Sorter Stapler 4	120/ 60	U. S. A.	A377 - 15	/
Ricoh ST25	120/ 60	U. S. A., etc.	A377 - 17	
	230/ 50	Europe, etc.		
NRG CSS55	120/ 60	U. S. A. , Canada, etc.	A377 - 22	
	230/ 50	Europe, etc.		
Infotec SS204	230/ 50	Europe	A377 - 26	